

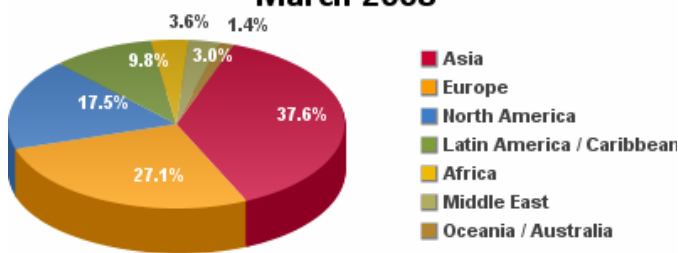

**Advantech Wireless – your partner for IP trunking over Satellite**

Internet Protocol is the world's most successful and widely used data oriented protocol for communicating across packet switched networks. Once regulated to handle only non-real-time traffic, IP (and the internet) have evolved and now supports essential real-time applications such as voice, video or other streaming media. Over 1.4 billion use Internet on a daily basis with growth exceeding 100% in key markets such as the Middle East, Africa and South America. As more of the worlds uses get connected, there will be ever increasing demands on delivery of IP traffic across the world.

**World Internet Users  
March 2008**



Source: [www.internetworldstats.com/stats.htm](http://www.internetworldstats.com/stats.htm)  
Copyright © 2008, Miniwatts Marketing Group

**Internet Users Growth in the World  
Between 2000 and 2008**

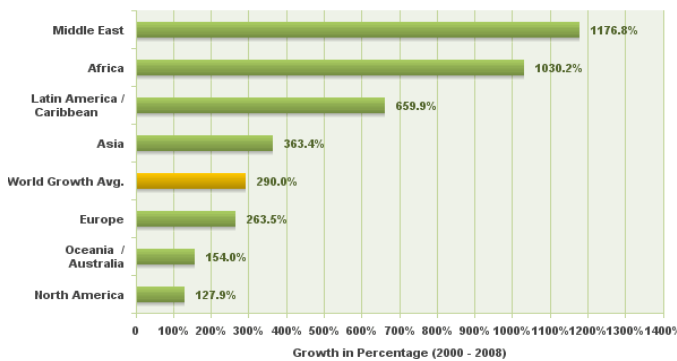

Note: World Internet Users estimate is 1,407,724,920 for Q1 2008.  
Copyright © 2008, Miniwatts Marketing Group - [www.internetworldstats.com](http://www.internetworldstats.com)

The Advantech AMT75 High Speed DVB-S/S2 modem is ideally suited for providing advanced high speed Ethernet and IP trunking to carriers and service providers. Essential to supporting this capability is Advantech's new IPE-422 interface card which, in addition to providing rich Ethernet and IP feature and MPEG encapsulation capability, also supports a special Mode Adaptation mode which is used to support Adaptive Coding and Modulation (ACM). ACM is an important evolution in DVB-S2 intended to provide high link assurance and optimization. As the name implies, the coding and modulation of the DVB-S2 system will adaptively and errorlessly adjust to changing environmental conditions. This means that instead of risk losing the connection due to heavy fading, ACM will adjust the modem performance to maintain the connection and increase the total up-time and availability.

In support of point-to-point Ethernet/IP trunking solutions, ACM monitors, in real time, the performance of the link and, the system automatically adjust the coding and modulation in order to maximize the capacity-availability ratio at any given time. Additionally, the ACM benefit can be used in conjunction or independently of an Automatic Uplink Power Control (AUPC) policy to

dynamically adjust the link coding and modulation to provide best BER results and highest possible link availability. This is especially valuable for IP links since high BER is essential to reduced re-transmission attempts and optimal link utilization.

The granularity of coding rates and range of modulation schemes allow for micro to macro adjustments of coding and modulation to assure link availability and compensate for any fade situation. A protected and highly robust Physical Layer Frame (L2 framing) is used to manage the ACM ensuring that that information is always available for the demodulator to correctly track the coding and modulation for the received encapsulated packet.

## LAN capabilities:

**Ethernet/VLAN bridging (L2 forwarding):** for point-to-point traffic transparency. Each modem builds local and remote MAC address tables minimizing traffic forwarding to only those Ethernet packets destined for the other side. This mode is ideal when the customer wants to transparently interconnecting customer furnished routers supporting MPLS, IP BGP, or other advanced routing protocols which may use the bridge simply as a forwarding point. In Ethernet bridging mode, the IPE supports either low overhead transport HDLC or frame relay or alternatively over MPEG.

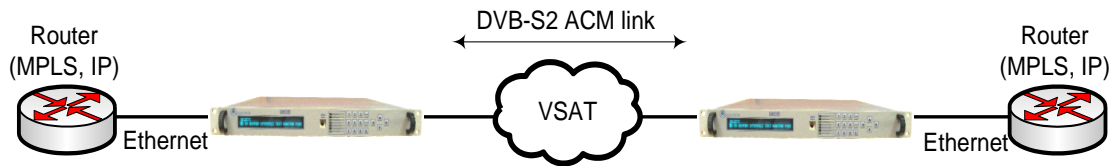

Example: AMT75 in point-to-point bridged network

**IP Forwarding (L3 forwarding):** for point-to-point or point-to-multipoint traffic support. The IPE supports Static routing (static pre-defined IP mapping), as well as standard dynamic routing environments such as IP RIP/RIP2 and OSPF, eliminating the need for separate routers at the remotes and providing a dynamic IP link restoration mechanism in case of link outages.

When deployed as IP Forwarding, other value added standard features such as DHCP, NAT/PAT, access lists and AAA makes integration into existing networks with different topologies simple. Advanced Quality of Service (QOS) features ensure control and priority is available on the IP traffic. Additionally, IP oriented connectivity, diagnostics and control is possible through useful features such as Ping, Telnet, and SNMP V1 and V3. Similar to bridging, in IP Forwarding mode, the IPE supports either MPEG, HDLC or frame relay over a satellite carrier.

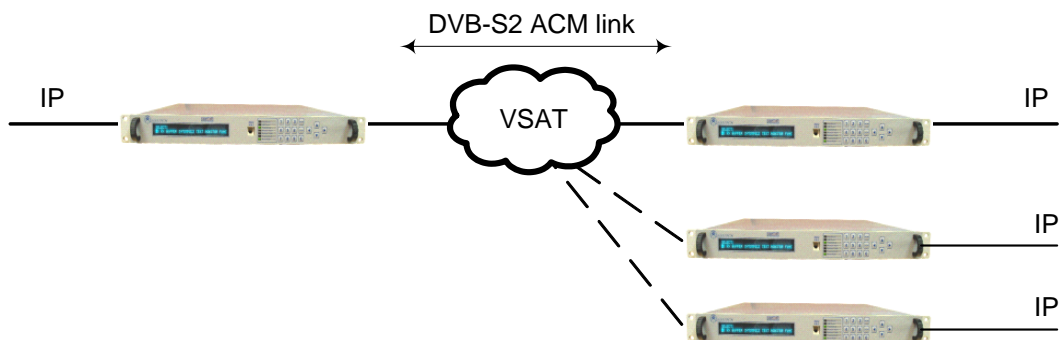

Example: AMT75 in point-to-point or point-to-multipoint routed IP network

## QOS and Traffic shaping:

The IPE-422 provides effective QOS and integral traffic shaping functions allowing for managed IPE output to match the modem speed. In ACM, the dynamic coding and modulation implies that speeds for individual links may vary as link conditions change. Traffic management is essential to minimize effect of ACM on traffic jitter and delay.

### NORTH AMERICA

USA  
Tel: +1 703 788-6882  
Fax: +1 703 788-6511  
info.usa@advantechwireless.com

### CANADA

Tel: +1 514 420-0045  
Fax: +1 514 420-0073  
info.canada@advantechwireless.com

### EUROPE

UNITED KINGDOM  
Tel: +44 1480 357 600  
Fax: +44 1480 357 601  
info.uk@advantechwireless.com

### RUSSIA & CIS

Tel: +7 495 967 1859  
Fax: +7 495 967 30 24  
info.russia@advantechwireless.com

### SOUTH AMERICA

BRAZIL  
Tel: +55 11 3054 5701  
Fax: +55 11 5041 4026  
info.brazil@advantechwireless.com

An ISO 9001 : 2008 Company

