

16W to 250W
SSPB-2000X® series



Features

- Converts L-Band signal to X-Band frequency
- Integrated amplifier with an output power from 16W to 250W
- Phase-locked oscillator to external 10MHz reference
- High linearity (low intermodulation products)
- Weatherproof package
- Field-Replaceable Power Supply
- Remote Monitor & Control
- Protection against thermal runaway and out-of-lock conditions
- Output sample monitoring port
- Built-in power supply
- Compact packaging
- CE Marking

Overview

The SSPB-2000X® series are hub-mount up-converter transmitters, operating in the X-Band. The SSPB-2000X® is an integrated unit, complete with power supply, phase-locked oscillator, mixer, filter and cooling mechanism. Intended for outdoor operation, the SSPB-2000X® provides the utmost in convenience and efficiency. Other SSPB's are also available for higher powers or for operation at other up-link frequencies.

The design of these units is based on Advantech Wireless industry proven reliable solid-state high power amplifiers. Built-in design features and assembly methods incorporated with efficient combining techniques result in an amplifier with exceptional linearity and operating efficiency. The use of high efficiency power supply and conservative thermal designs contribute to the trouble-free operation of the amplifier. Built-in microprocessor controller provides the capability for serial port interfaces (RS232/485) for remote monitoring and control.

Application

The SSPB-2000X® series convert an L-Band signal to the X-band frequency. Designed for X-Band satellite up-link applications, the SSPB series are available in output power from 10W to 1000W. The SSPB-2000X® series are fully integrated units with 16W to 250W output power designed for mounting outdoors, near the hub of an antenna.

Advantech Wireless SSPB product line includes variety of units operating in various satellite band frequencies with full range of output power levels. Please contact Advantech Wireless for additional information.

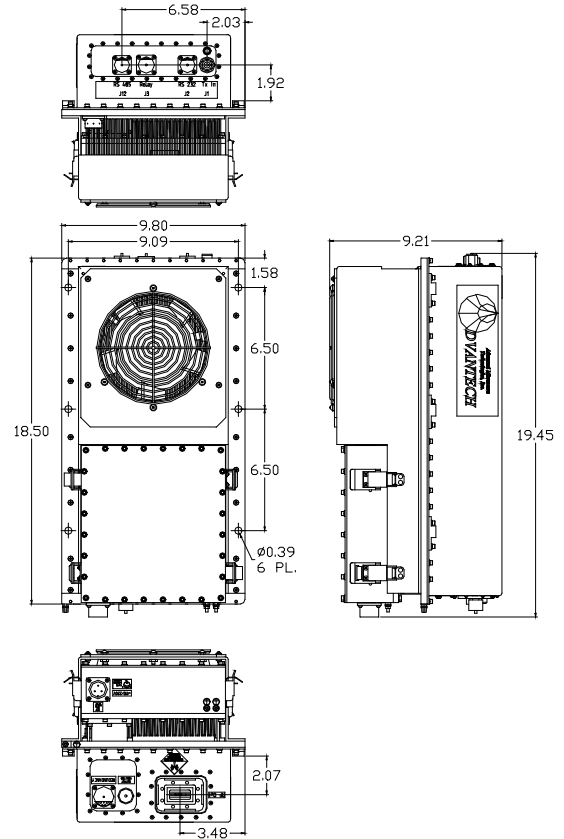

Options

- High performance external Receive Reject Filter
- Internal High Stability 10MHz Reference
- Redundant System
- Remote M&C panel (Ethernet port optional)

Redundancy

The SSPB-2000X® series are available in redundant configuration with single Monitor and Control interface. Redundancy kits are required for redundant operation.

X-Band Hub-mount SSPB

Technical Specifications	16W	20W	25W	30W	40W	50W	60W	80W	100W	125W	150W	200W	250W					
Electrical Characteristics																		
Output power (P _{SAT}) dBm	+42	+43	+44	+45	+46	+47	+48	+49	+50	+51	+52	+53	+54					
Output power (P _{1dB}) min dBm	+41	+42	+43	+44	+45	+46	+47	+48	+49	+50	+51	+52	+53					
Conversion gain @ maximum setting at ambient temperature dB	62	63	64	65	66	67	68	69	70	71	72	73	74					
L-Band input frequency	950 - 1450 MHz																	
RF Output frequency	7.9 – 8.4 GHz																	
Max input power without damage	+10 dBm																	
Gain flatness	± 2.0 dB max full band, 0.3 dB/10 MHz																	
Gain variation over temperature	3.0 dB p-p max -30°C to +55°C																	
Gain adjustment range	20 dB																	
Input return loss	18 dB, min																	
Output return loss	20 dB, min																	
Noise Power Density	-70dBm/Hz in TX band, -110 dBm/Hz in RX band																	
Spurious at rated power	-60 dBc, max																	
Harmonics at rated power	-75 dBc, max																	
AM/PM conversion	2.5°/dB typical (at P _{1dB})																	
Third order IMD (2 tones)	-24 dBc, max at 3 dB back-off from P _{1dB}																	
Local Oscillator frequency (LO)	6.950 GHz																	
LO leakage	-20 dBm																	
Phase noise*	-60 dBc/Hz at 10Hz			-73 dBc/Hz at 1000Hz			-93 dBc/Hz at 100 kHz			-63 dBc/Hz at 100Hz			-83 dBc/Hz at 10 kHz			-110 dBc/Hz at 1 MHz		
Group Delay (over any 40 MHz):	Linear		0.02 ns /MHz, max		Parabolic		0.003 ns/MHz ² , max		Ripple		1 nsec p-p, max							
External reference																		
Reference frequency	10 MHz																	
Reference frequency phase noise	-115 dBc/Hz at 10 Hz			-135 dBc/Hz at 100 Hz			-148 dBc/Hz at 1000 Hz			-150 dBc/Hz at 10 kHz			-160 dBc/Hz at 100 kHz					
Reference frequency level	0 dBm ± 5 dB																	
(For 1:1 redundant operation, internal 10MHz reference is recommended)																		
Power Requirements																		
AC input voltage	110/220 VAC (47-63 Hz) auto ranging																	
Power consumption (nominal)	550W	600W	700W	800W	1000W	1250W	1500W	1600W										
Mechanical Characteristics																		
Dimensions (L x W x H)	16.5"x10"x9" (42.0x254x22.9 cm)							18.50"x 9.80" x 9.56" (46.99 x 254.9 x 24.28 cm)										
Weight	36 lbs (16 Kg)							44 lbs (20 Kg)										
Interfaces:	RF input	Type N (F)	Redundancy	MS3112E16-	RF output	CPR-112G												
	Relay port	MS3112E12-10P	26P															
	AC Line	MS3102R16-10P	RS-232	MS3112E10-6P														
			RS-485	MS3112E10-6P														
Environmental Conditions																		
Temperature:	Operating	-30°C to +55°C; <i>Option 1: -40°C to +55°C; Option 2: -50°C to +50°C</i>																
	Storage	-55°C to +85°C																
Humidity	100%, condensing (2" rain/hour)																	
Altitude	10,000' AMSL, de-rated 2°C/1,000' from AMSL																	

* Based on internal 10MHz Reference.

NORTH AMERICA
USA
Tel: +1 678 889-1831
Fax: +1 678 889-1756
info.usa@advantechwireless.com

CANADA
Tel: +1 514 420 0045
Fax: +1 514 420 0073
info.canada@advantechwireless.com

EUROPE
UNITED KINGDOM
Tel: +44 1480 357 600
Fax: +44 1480 357 601
info.uk@advantechwireless.com

RUSSIA & CIS
Tel: +7 495 971 59 18
info.russia@advantechwireless.com

SOUTH AMERICA
USA
Tel: +1 678 889-1831
Fax: +1 678 889-1756
info.latam@advantechwireless.com

BRAZIL
Tel: +55 11 3054 5701
Fax: +55 11 3054 5701
info.brazil@advantechwireless.com

An ISO 9001 : 2008 Company



Ref.: PB-SSPB-X-16-250-12106