



10W to 25W
SSPB-210C® series



Features

- Up-converts an L-Band input frequency (950 – 1525 MHz) to a standard
- Output power to 25W
- Phase-locked local oscillator locks directly to an external 10 MHz reference
- Exceeds IESS 308/309 Phase/Noise requirements by 3 dB
- Robust, weatherproof package
- RS-485/RS232 serial Interface for remote Monitoring and Control
- Sample port
- Protection against thermal runaway and out-of-lock conditions
- CE Marking

Overview

The SSPB-210C® series is hub-mount up-converter transmitters, operating in the C-Band. The SSPB-210X® is an integrated unit, complete with power supply, phaselocked oscillator, mixer, filter and cooling mechanism. Intended for outdoor operation, the SSPB-210C® provides the utmost in convenience and efficiency. Other SSPBs are also available for higher powers or for operation at other up-link frequencies.

The hub-mount SSPB-210C® is constructed in a compact cooling enclosure for outdoor operation. The units are weatherproof. They are the smallest fully integrated units on the market today.

The design of these units is based on Advantech's industry proven reliable solid-state high power amplifiers. Built-in design features result in a product with exceptional linearity and operating efficiency. The use of high efficiency power supply and conservative thermal designs contribute to the trouble-free operation of the unit.

Built-in microprocessor controller provides the capability for serial port interfaces (RS485) for remote monitoring and control.

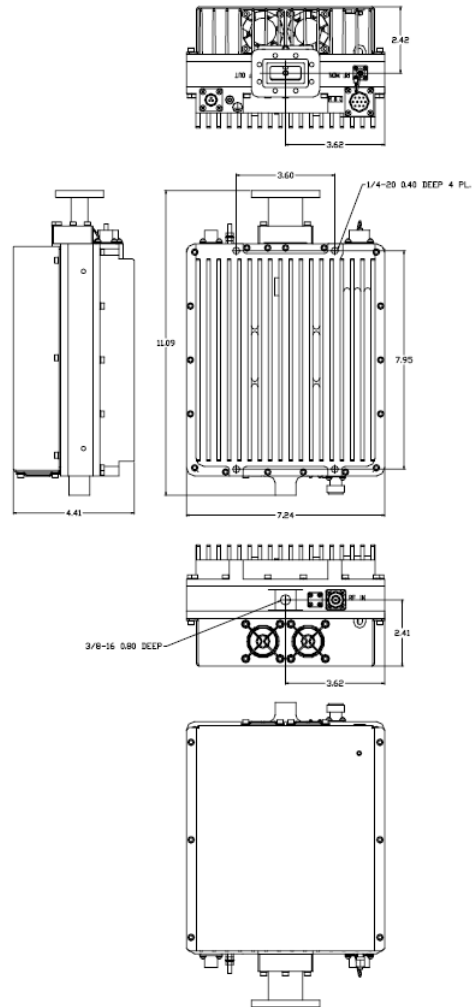

Application

The SSPB's convert an L-Band signal (950-1525 MHz) to the C-band frequency (5.85 – 6.425 GHz). Designed for C band satellite up-link applications the SSPB-210C® series is fully integrated units up to 20W output power designed for mounting outdoors, near the hub of an antenna.

C-Band SSPB is available in output power of up to 1000W.

Options

- Optional AC Power
- Separate power connector for 10W
- Ethernet port

Accessories

- Mounting kit
- Hand Held Terminal

C-Band Block Up Converter

Technical Specifications	10W	16W	20W	25W
Electrical Characteristics				
Output power (P1dB) min	+40 dBm	+41 dBm	+42 dBm	+43 dBm
Conversion gain min.	+61 dB	+62 dB	+63 dB	+64 dB
Input /Output frequency range	L-Band 950-1525 MHz / C-Band 5.85 – 6.425 GHz			
Input Level	-22 dBm for P1Db			
Gain flatness	3.0 dB p-p, typical over 575MHz, 1.0 dB p-p /40 MHz			
Attenuation range	20 dB typical			
Gain variation over temperature	3.0 dB max over full operating range			
Input VSWR, in-band	1.4: 1			
Output VSWR	1.5: 1			
Input impedance	50 Ω			
Noise Power Density	-145 dBm/Hz in 3.4 – 4.2 GHz			
Spurious (in-band) at rated power	-60 dBc, max			
AM/PM conversion	3°/dB typical (at P _{1dB})			
Third order IMD (2 tones)	-26 dBc, max at 3 dB total back-off from P _{1dB}			
Local Oscillator frequency (LO)	4.9 GHz			
LO leakage	< -20 dBm			
Phase noise	-55 dBc/Hz at 10Hz -65 dBc/Hz at 100Hz -73 dBc/Hz at 1000Hz	-83 dBc/Hz at 10 kHz -105 dBc/Hz at 100 kHz -110 dBc/Hz at 1 MHz		
Group Delay (over any 40 MHz):	Linear Parabolic Ripple	0.02 ns /MHz, max 0.003 ns/MHz ² , max 1 nsec p-p, max		
Rejection in receive band	-55 dBc			
External reference				
Reference frequency	10 MHz			
Recommended reference frequency phase noise	-115 dBc/Hz at 10 Hz -135 dBc/Hz at 100 Hz -148 dBc/Hz at 1000 Hz	-150 dBc/Hz at 10 kHz -160 dBc/Hz at 100 kHz		
Reference frequency level	0 dBm ± 5 dB			
Power Requirements				
Supply voltage	10W 16W/20W	40 V to 60 V DC (via L-Band cable) or optionally on a separate connector 40V to 60V DC or 110/220 VAC auto-ranging 40V to 60V DC or 110/220 VAC auto-ranging		
Power consumption (nominal)	95W	145W	160W	170W
Mechanical Characteristics				
Dimensions (W x H x L)	18.39 x 11.20 x 28.17 cm (7.24" x 4.41" x 11.09") DC operation 18.39 x 12.45 x 28.17 cm (7.24" x 4.91" x 11.09") AC operation			
Weight	5 kg (11 lbs)			
Finish	White			
Interfaces:	RF input Type N (F) Output Monitor SMA-F RF output CPR137 grooved RS-485/RS-232 Serial Port MS3112E12-10P Ethernet port RJ45 (option) MS3102R10SL-3P (AC option) or MS3102R10S-4P (DC option)			
Environmental Conditions				
Temperature:	Operating	-30°C to +55°C		
	Storage	-55°C to +85°C		
Humidity		100%, condensing		
Altitude		10,000' AMSL, de-rated 2°C/1,000' from AMSL		

NORTH AMERICA
USA
Tel: +1 678 889-1831
Fax: +1 678 889-1756
info.usa@advantechwireless.com

CANADA
Tel: +1 514 420 0045
Fax: +1 514 420 0073
info.canada@advantechwireless.com

EUROPE
UNITED KINGDOM
Tel: +44 1480 357 600
Fax: +44 1480 357 601
info.uk@advantechwireless.com

RUSSIA & CIS
Tel: +7 495 971 59 18
info.russia@advantechwireless.com

SOUTH AMERICA
USA
Tel: +1 678 889-1831
Fax: +1 678 889-1756
info.latam@advantechwireless.com

BRAZIL
Tel: +55 11 3054 5701
Fax: +55 11 3054 5701
info.brazil@advantechwireless.com

An ISO 9001 : 2008 Company



Ref.: PB-SSPBm-C-10-25-12106